

INSTRUCTION MANUAL

WOW FLUTTER METER

MODEL 677C

KIKUSUI ELECTRONICS CORPORATION, JAPAN

77.11.9

771476C

Power Requirements of this Product

Power requirements of this product have been changed and the relevant sections of the Operation Manual should be revised accordingly.

(Revision should be applied to items indicated by a check mark)

Input voltage

The input voltage of this product is _____ VAC,
and the voltage range is _____ to _____ VAC. Use the product within this range only.

Input fuse

The rating of this product's input fuse is _____ A, _____ VAC, and _____.

WARNING

- To avoid electrical shock, always disconnect the AC power cable or turn off the switch on the switchboard before attempting to check or replace the fuse.
- Use a fuse element having a shape, rating, and characteristics suitable for this product. The use of a fuse with a different rating or one that short circuits the fuse holder may result in fire, electric shock, or irreparable damage.

AC power cable

The product is provided with AC power cables described below. If the cable has no power plug, attach a power plug or crimp-style terminals to the cable in accordance with the wire colors specified in the drawing.

WARNING

- The attachment of a power plug or crimp-style terminals must be carried out by qualified personnel.

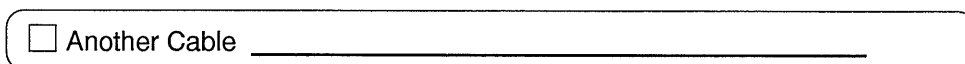
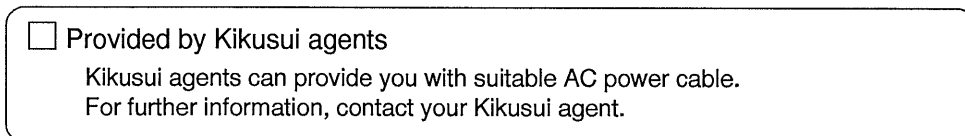
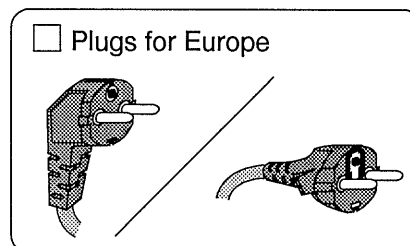
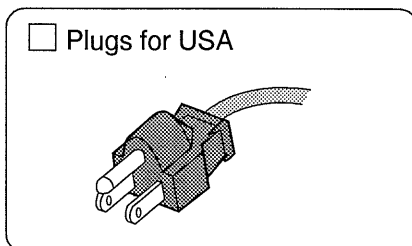
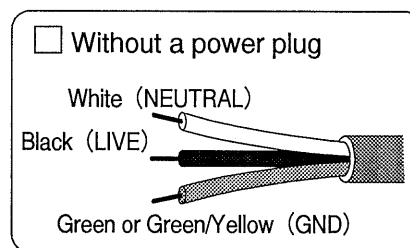
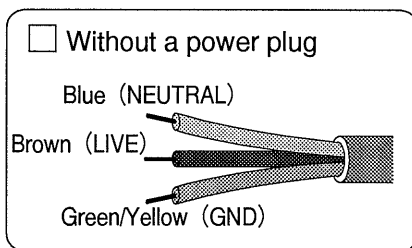

TABLE OF CONTENTS

	<u>PAGE</u>
1. GENERAL	1
2. SPECIFICATION	2
3. OPERATION INSTRUCTIONS	5
3.1 Explanation of Front Panel	5
3.2 Explanation of Rear Panel	7
3.3 Explanation of Side Panel	8
3.4 Operation Procedure	11
3.5 Notes in Operation	14
4. OPERATING PRINCIPLE	16
4.1 Definition of Wow/Flutter	16
4.2 Operating Principle	17
5. MAINTENANCE	20
5.1 Calibration	20
5.2 Notes in Calibration	20
5.3 Calibration Procedure	20

771477

1. GENERAL

Model 677C Wow Flutter Meter measures wows and flutters of various sound record/playback devices such as audio tape recorders, video tape recorders, disc record players, and cine sound recorders, etc. in various measuring systems as follows:

- o Effective value indication as per JIS Standard.
- o Mean value indication as per NAB Standard.
- o Peak value indication as per CCIR Standard.
- o Peak value indication as per DIN Standard.

The tape speed is digitally displayed with a 4-digit frequency counter. The frequency counter can also be used as an independent frequency indicator for a range of 10 Hz - 9999 Hz.

The instrument has a SCOPE terminal and a RECORDER terminal which provide signals for observation, recording, and analysis of waveforms and periods of wows and flutters.

The instrument provides a very effective means of wow and flutter measurement for research, manufacturing, inspection and maintenance of audio and video recording and reproducing devices.

2. SPECIFICATION

Model No.:	677C
Measuring center frequency ranges:	Within 3000 Hz \pm 150 Hz (JIS, NAB, CCIR) 3150 Hz \pm 150 Hz (DIN)
Input level range:	5 mV ~ 10 V _{rms} (irrespective of amplitude), (in 2 ranges of 5 mV ~ 10 V _{rms} and 50 mV ~ 10 V _{rms})
Input impedance:	330 k Ω \pm 20%, single-ended
Input terminal:	5-way type, distance 19 mm (3/4 in.)
Wow/flutter measuring range:	0.005 ~ 3% (in 4 ranges of 0 ~ 0.1%, 0 ~ 0.3%, 0 ~ 1%, and 0 ~ 3%)
Wow/flutter indication system:	Effective-value indication as per JIS Mean value indication as per NAB Peak value indication as per CCIR or DIN
Wow/flutter indication accuracy:	Better than \pm 5% of full scale, for each range.
Wow/flutter frequency characteristics:	(Depend upon frequency characteristics of wow/flutter measuring filter)
Weighted characteristics:	Weighted (hearing-sense compensation) characteristics of JIS, NAB, CCIR, and DIN Standards
Wow/flutter separation characteristics:	Wow 0.5 ~ 6 Hz Flutter 6 ~ 200 Hz

Flatness characteristics

JIS, NAB (4 Hz reference)

-3 dB \pm 1 dB at 0.5 Hz, 200 Hz

Attenuates with -6 dB/OCT or over at frequencies lower than 0.5 Hz

Attenuates with -15 dB/OCT or over at frequencies higher than 200 Hz

CCIR, DIN (4 Hz reference)

-3 dB \pm 1 dB at 0.3 Hz, 200 Hz

Attenuates with -6 dB/OCT or over at frequencies lower than 0.3 Hz

Attenuates with -15 dB/OCT or over at frequencies higher than 200 Hz

Tape speed (measuring center frequency)

Indication system: 4 digits, storage indication system,
7-segment LED figures,
gate time 1 sec.

Indication range: 2700 Hz ~ 3500 Hz at least

Frequency counter

Measuring frequency range: 10 Hz ~ 9999 Hz

Gate time: 1 sec

Measuring accuracy: $\pm(1 \text{ count} + \text{reference frequency accuracy})$

Measuring unit: Hz

Reference frequency: 1.26 MHz, accuracy $\pm 5 \times 10^{-5}$ or better

Indication system: Same with that of Item "Tape speed"

Input level range: 50 mV ~ 10 V_{rms} (irrespective of amplitude)

Internal oscillator (sine wave oscillator for recording)

Oscillating frequency: 3000 Hz and 3150 Hz

Frequency accuracy: $\pm 5 \times 10^{-5}$ (at 20°C $\pm 10^\circ\text{C}$ (68°F $\pm 18^\circ\text{F}$))

Output voltage: 0.3 V_{rms} or over (open terminal)

Distortion factor: Less than 2%

Output impedance: 600 Ω $\pm 20\%$ (single-ended)

Output terminal: 5-way type, distance 19 mm (3/4 in.)

Wow/flutter signal output terminals: SCOPE terminal and RECORDER terminal;
5-way type, distance 19 mm (3/4 in.)

Operating temperature and humidity range: 5 ~ 35°C (41 ~ 95°F), less than 85% RH

Power requirements: 100V AC $\pm 10\%$, 50/60 Hz, approx. 36 VA
(Voltage is convertible to 110, 117, 220, 230 or 240 V with voltage taps of internal transformer.)

Dimensions: 200 (W) x 140 (H) x 370 (D) mm
(7.87(W) x 5.51(H) x 14.57(D) in.)

(Maximum dimensions): 203 (W) x 163 (H) x 412 (D) mm
(8.00(W) x 6.42(H) x 16.22(D) in.)

Weight: Approx. 7.6 kg (16.8 lb.)

Accessories: Operation Manual 1

771481C

3. OPERATION INSTRUCTIONS

3.1 Explanation of Front Panel (Refer to Fig. 3-1.)

- (1) POWER: ON-OFF switch for main instrument power. When this switch is turned ON, the power is supplied to the instrument and the power pilot lamp (green LED) lights.
- (2) INPUT: Input terminal for applying the signal to be measured (from record/playback device). GND terminal is connected to chassis.

Wow/flutter measurement: 3 kHz \pm 150 Hz
3.15 kHz \pm 150 Hz

Frequency measurement: 10 Hz ~ 9999 Hz

- (3) PUSH 5 mV: Input sensitivity selector switch. Popped-up state is for input sensitivity 50 mV_{rms}; depressed and locked state is for input sensitivity 5 mV_{rms}. Maximum allowable input voltage is 10 V_{rms} for both states.
- (4) PUSH COUNTER: Frequency counter input selector switch. When this switch is depressed and locked, the instrument operates as a frequency counter and indicates the frequency of the INPUT signal.
- (5) RANGE (%): Wow/flutter measuring range selector switch. Selects 4 ranges of 0.1%, 0.3%, 1.0%, and 3.0% for full-scale values. Measurement becomes effective when corresponding button is depressed and locked.

- (6) MODE: Wow/flutter measuring mode selector switch for the following modes. Measurement becomes effective when corresponding button is pushed and depressed.
- * WEIGHTED: For wow/flutter measurement with hearing-sense compensation as per JIS, NAB, CCIR, or DIN Standard.
 - * WOW: For measurement of wow component (0.5 ~ 6 Hz) alone separated from the measured signal.
 - * FLUTTER: For measurement of flutter component (6 ~ 200 Hz) alone separated from the measured signal.
 - * LINEAR: For measurement of all wow/flutter components of the measured signal as per JIS, NAB, CCIB, or DIN Standard.
- (7) INDICATION: Wow/flutter indication system (measuring standard) selector switch. Measurement becomes effective when corresponding button is pushed and depressed.
- * JIS: Wow/flutter are measured as per JIS Standard.
 - * NAB: Wow/flutter are measured as per NAB Standard.

- * CCIR: Wow/flutter are measured as per CCIR Standard.
 - * DIN: Wow/flutter are measured as per DIN Standard.
- (8) WOW/FLUTTER % INDICATOR: Directly indicates the quantity of wow/flutter. Dual scales of "1" and "3" corresponding to RANGE %.
- (9) TAPE-SPEED/FREQUENCY (Hz): Indicates tape speed or frequency, with 7-segment LED display of 4 digits. The unit of measure is Hz. Also indicates input level. Normally, where there is no input signal, the digits are OFF (does not light). When the input level is at the required level, digits light indicating that the instrument is ready for measurement.
- (10) OVER: Over-range indicator lamp. Lights when input signal is higher than 9999 Hz, in which case the frequency counter reads "0000".

3.2 Explanation of Rear Panel (Refer to Fig. 3-2.)

- (11) TO SCOPE: This terminal provides a signal for observation of wow/flutter waveform (period) with an oscilloscope. GND terminal is connected to chassis. Output impedance is approximately 10 k Ω .

771484

- (12) TO RECORDER: This terminal provides a signal for recording of drift (tape speed) and wow/flutter waveform. GND terminal is connected to chassis. Output impedance is approximately 10 k Ω .
- (13) INT OSC OUT
3 kHz/3.15 kHz: This terminal provides the output of the sine wave oscillator for recording. Frequency is 3 kHz when other standard than DIN is selected or it is 3.15 Hz when DIN is selected. GND terminal is connected to chassis.
- (14) FUSE: Tubular glass fuse of 1 A (slow blow type) in AC power line.
- (15) POWER CORD: Connect to AC power line receptacle (V, 50/60 Hz AC).

3.3 Explanation of Side Panel (Refer to Fig. 3-3.)

This panel indicates the components which are to be adjusted for instrument calibration. The panel can be readily removed simply by removing the screws at both ends. When the panel is removed, components (semi-fixed potentiometers) are accessible in the positions corresponding to indications on the panel.

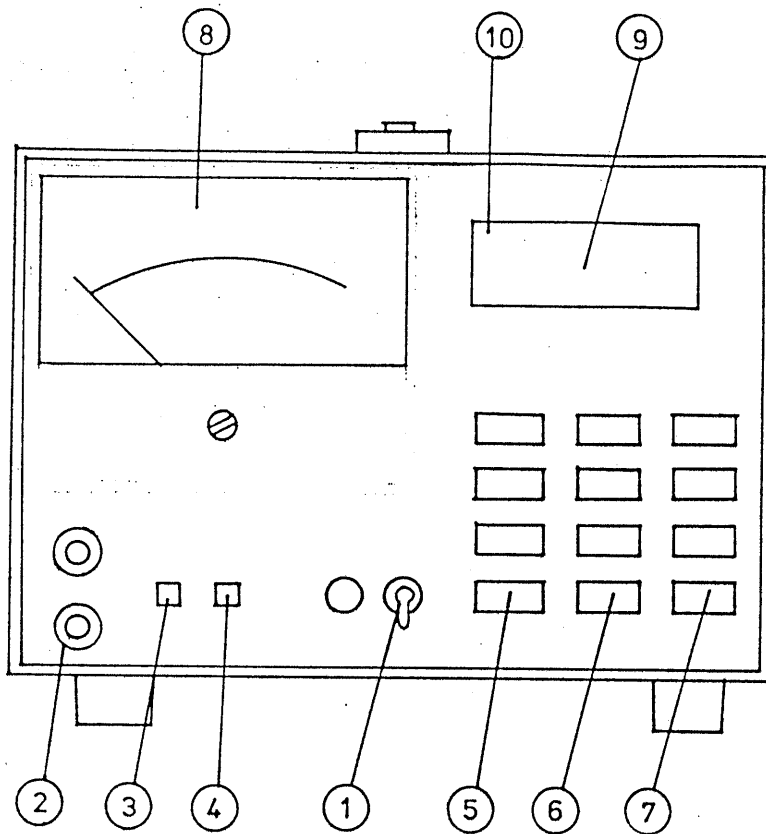

Fig. 3-1 Layout of components on front panel

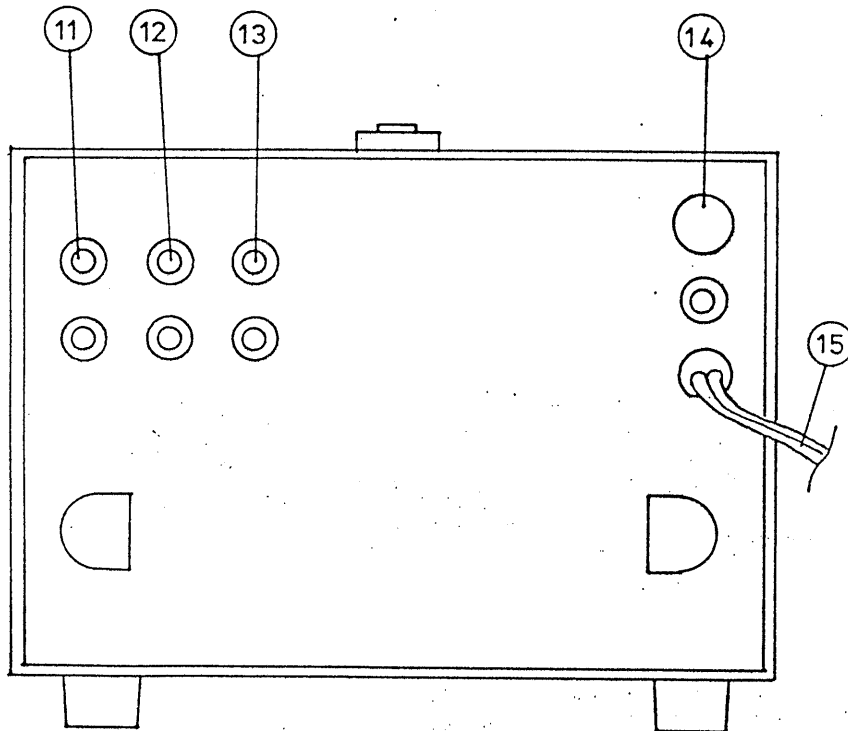

Fig. 3-2 Layout of components on rear panel

771436c

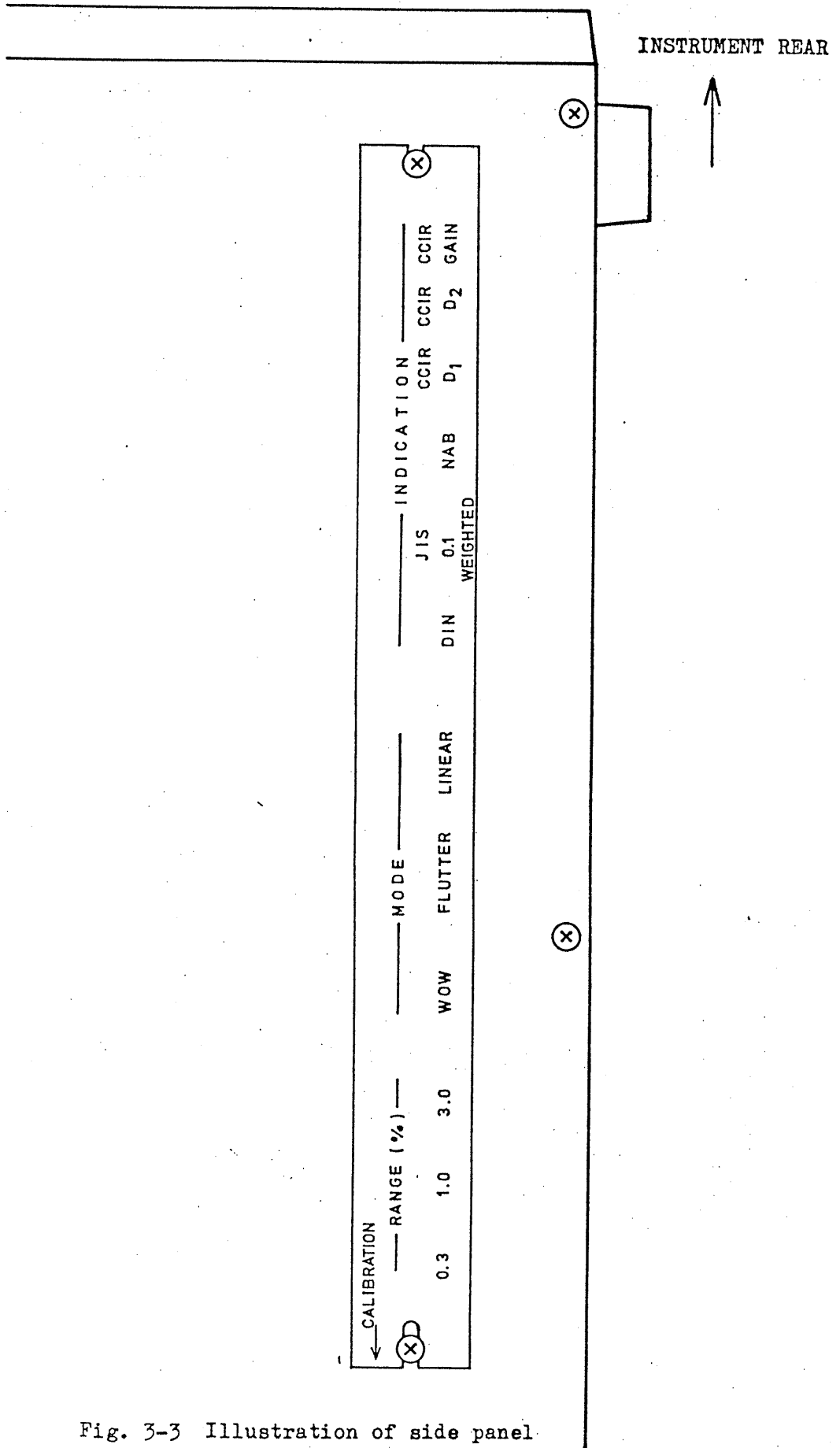

Fig. 3-3 Illustration of side panel.

771487

3.4 Operation Procedure

3.4.1 Turn-OFF the POWER switch. Connect POWER cord to an AC line receptacle. Set panel switches as follows:

PUSH 5 mV:	Popped-up state
PUSH COUNTER:	Popped-up state
RANGE (%):	3.0
MODE:	Normally, WEIGHTED or LINEAR
INDICATION:	JIS, NAB, CCIR, or DIN, as required.

3.4.2 Turn-ON the POWER switch. The power pilot lamp (green LED) will light.

3.4.3 If the tested object is a tape recorder and recording is required before testing or if the object is required to be tested recording and reproducing at the same time, connect the INT OSC OUT 3kHz/3.15kHz terminal on the rear panel of the 677C to the input of the tested object.

* Either 3 kHz or 3.15 kHz should be used in accordance with the industrial standard applied. Refer to 3.5 "Notes in Operation."

Apply to the INPUT of 677C the measured signal produced by the tested object.

3.4.4 If the level of the signal applied to the INPUT is 50 mV_{rms} or higher, the TAPE SPEED/FREQUENCY (Hz) display unit digitally indicates the input signal frequency, indicating that the 677C is in the measuring status. If the input signal level is lower than 50 mV_{rms}, depress the PUSH 5mV button so that the input sensitivity is increased and the required input signal level effectively becomes 5 mV_{rms} or higher.

771488C

- * In the above case, even if the TAPE SPEED/FREQUENCY (Hz) display unit is indicating a certain value, measurement is not reliable unless the indicated value is 3 kHz \pm 150 Hz (for JIS, NAB, or CCIR) or 3.15 kHz \pm 150 Hz (for DIN).

3.4.5 If the 677C is in the status of Par. 3.4.4 above, the instrument is in the measuring status. Observing the indicator, increase the instrument sensitivity by varying the RANGE % selector from 3.0 to 1.0 and 0.3 until the indicator pointer is deflected maximum without deflected over the full scale.

- * The tape speed can be directly read on the TAPE SPEED/FREQUENCY (Hz) display unit (in terms of Hz), irrespective of setting of control buttons (except PUSH COUNTER button) on the panel. The frequency indication range is 2700 Hz - 3500 Hz at least.

3.4.6 To measure the wow component alone, depress the WOW button for MODE setting. To measure the flutter component alone, depress the FLUTTER button.

- * In this case, measurement is made irrespective of standards selected by the INDICATION buttons.

3.4.7 To observe the waveform and period of the wow/flutter measuring signal, connect an oscilloscope to the TO SCOPE terminal of the 677C.

- * An output corresponding to the MODE and RANGE % selectors is provided. To record drift (tape speed), connect a recorder to the TO RECORDER terminal. If a high speed oscillograph is used, drift and wow/flutter can be recorded at the same time.

- * The signal is not affected by setting of the RANGE %, MODE, and INDICATION selector buttons on the panel. The signal polarity is "-" (negative) for "+" (positive) direction deviation of tape speed.

3.4.8 To operate the 677C as a frequency counter, depress the PUSH COUNTER button and apply to the INPUT terminal the signal to be measured. If the applied signal level is not lower than $50 \text{ mV}_{\text{rms}}$, the digital display unit indicates the input signal frequency.

- * When the 677C is set as a frequency counter, the function of the PUSH 5mV_{rms} and other buttons on the panel are idle and the instrument does not operate as a wow/flutter meter.
- * If the input signal frequency is higher than 9999 Hz, the OVER lamp flickers and the digital display unit indicates "0000".

3.5 Notes in Operation

- 3.5.1 The indicated value substantially differs by the standard applied (setting of the INDICATION and MODE selectors). Since no standards are available on separate measurement of wow and flutter, use the MODE selector (WOW and FLUTTER buttons) for laboratory analysis, etc.
- 3.5.2 If the input signal level and frequency is not within the specified ranges of the 677C, the TAPE SPEED/FREQUENCY (Hz) display unit does not light (refer to Par. 3.4.4, 3.4.8). However, if the level is sufficiently high, the display unit indicates a certain value even when the frequency is not within the specified range. Therefore, for wow/flutter measurement, ensure that the center frequency range is within the specified range.
- 3.5.3 When the input signal (the output signal of the record/playback device tested) is sufficiently high (more than $50 \text{ mV}_{\text{rms}}$), measurement should be made without depressing the PUSH 5 mV button. The wow/flutter indicator does not deflect over the full scale and noise-resistant stable measurement can be done.
- 3.5.4 The OVER lamp of the frequency counter is effective up to approximately 15 kHz. Note that, if the frequency is higher than this, all indications goes off and the observed states become as if no input were being applied. If the frequency is lower than 10 Hz, all indications flicker to alert the operator to this state.

771491C

3.5.5 The output frequency of the INT OSC OUT 3kHz/3.15kHz vary by setting of the INDICATION selector as follows:

- * 3 kHz JIS, NAB, CCIR
- * 3.15 kHz DIN

The output also varies slightly between 3kHz setting and 3.15kHz setting.

3.5.6 Regarding the RANGE %, MODE, and INDICATION selectors, do not depress two or more buttons at the same time. If two or more buttons are depressed, no reliable measurement can be expected.

3.5.7 The maximum allowable voltage of the INPUT terminal is 50 V. Regarding other terminals, do not directly connect them to a voltage source which has a superimposed DC component.

3.5.8 The specified environmental conditions are ambient temperature 5 ~ 35°C (41 ~ 95°F) and relative humidity less than 85%. Do not use the 677C under direct sunlight or near a heat source. Note that adverse environmental conditions (gas, dust, vibration, chemicals) shorten the life expectancy of the instrument.

4. OPERATING PRINCIPLE

4.1 Definitions of Wow/Flutter

Speed variation of an object in motion can be expressed in terms of percentage (%) as follows:

$$\frac{v - v_0}{v_0} \times 100 (\%)$$

where, v_0 : average speed
 v : instantaneous speed

This concept is applicable to measurement of relative speed change. Assume that a relative speed change (change of relative speed between head and tape) of a tape recorder is to be measured. Since speed and frequency are linearly proportional, speed change can be handled as frequency change. Therefore, relative speed change of the tape recorder can be expressed in terms of percentage as follows:

$$\frac{f - f_0}{f_0} \times 100 (\%)$$

where, f_0 : center frequency
 f : instantaneous frequency

Therefore, wow and flutter can be defined as variation in reproduced signal frequency due to variation of relative speed between signal detector and signal recording media of a tape recorder in operation. Slower frequency variations are called "wow" and faster frequency variations are called "flutter." Very slow variations are called "drift" and are distinguished from wow and flutter.

To put it in another way, wow and flutter causes such effect that center frequency f_0 is frequency modulated with the deviation of $f - f_0$. The factor of wow/flutter is corresponding to the depth of frequency modulation. Frequency variations are referred to as "drift", "wow", and "flutter"; as the variation speed becomes faster.

4.2 Operating Principle

Referring to the definition in Sub-section 4.1, wow/flutter can be measured by demodulating (discriminating) the frequency-modulated signal and determining the demodulated signal amplitude. A basic block diagram of the 677C is shown in Fig. 4-1. The concept diagram of wow/flutter meter is shown in Fig. 4-1.

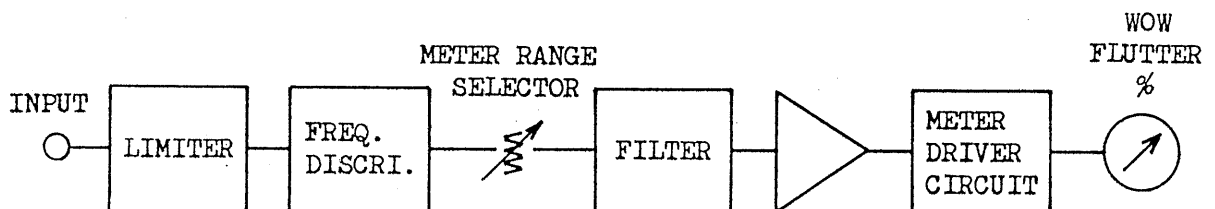

Fig. 4-1.

The input signal is fed through the limiter to the frequency discriminator for frequency-demodulation. The demodulated signal is fed through the meter range selector to the filter. The filter attaches "weight" to the signal in accordance with frequency change speed, in either one of the four modes of WEIGHTED, WOW, FLUTTER, and LINEAR.

- * WEIGHTED: Attaches weight to signal as specified by JIS, NAB, CCIR, or DIN in order to compensate for the sense of hearing of human being.

771494C

* WOW, FLUTTER: Separates into wow and flutter, with 6 Hz as the discriminating point between the two.

* LINEAR: Passes all components of wow and flutter. Characteristics are specified as is the case for WEIGHTED.

The signal weighted by the filter is amplified and fed to the meter driver circuit (indicator circuit) which drives the indicating meter. The indicator circuit provides the required characteristics for respective standards (JIS = effective value, NAB = mean value, CCIR/DIN = peak value) and it also controls dynamic characteristics of the indicating meter.

A block diagram of the 677C is shown in Fig. 4-2.

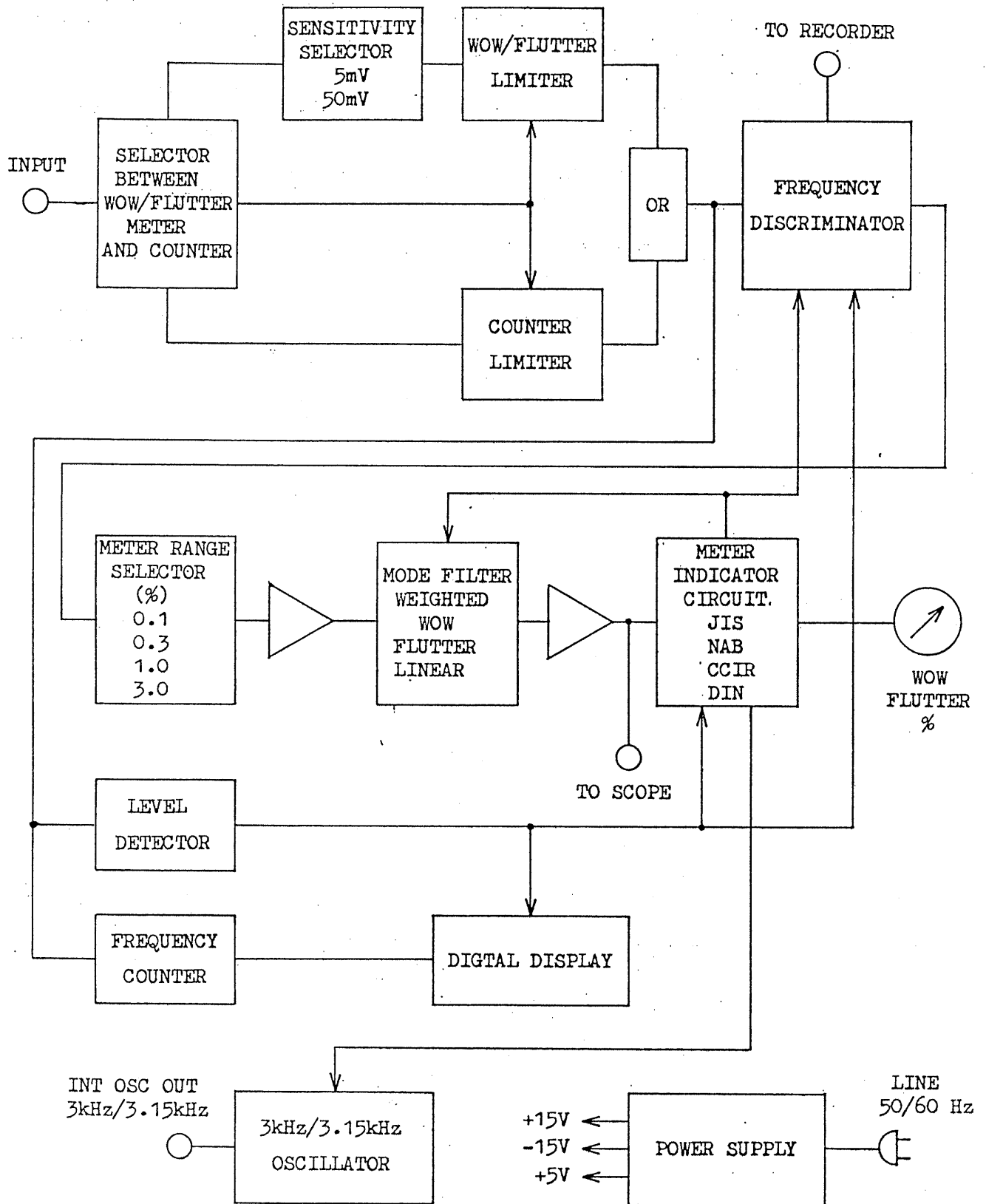

Fig. 4-2 Block diagram of the 677C

771496C

5. MAINTENANCE

5.1 Calibration

The 677C has been designed for long period reliable operation. To ensure reliability and accuracy, the instrument should recommendably be calibrated every six months.

5.2 Notes in Calibration

- 5.2.1 Before turning-on the instrument power, check mechanical zero of the indicating meter. If it has been shift, adjust it correctly.
- 5.2.2 Allow more than 5 minutes of stabilization period after turning-on the instrument power.
- 5.2.3 Fully stabilize the calibrating equipment also.
- 5.2.4 Ambient temperature should be $20^{\circ}\text{C} \pm 10^{\circ}\text{C}$ ($68^{\circ}\text{F} \pm 18^{\circ}\text{F}$).

5.3 Calibration Procedure

Remove the calibration panel on the right-hand side of the instrument, by sliding it after loosening its two clamping-screws. Potentiometers for calibration are accessible in positions corresponding to indications on the panel.

- * Calibration must be carried out in the below-mentioned order. Set the wow/flutter calibrator at center frequency 3 kHz and output voltage about $1 V_{\text{RMS}}$, unless specified otherwise.

771497C

5.3.1 Calibration of Meter Sensitivity and Range (%)

(1) Depress the following switches on the front panel:

- * RANGE % 0.1
- * MODE WEIGHTED
- * INDICATION JIS

(2) Apply to the 677C a signal frequency-modulated with a wow/flutter frequency of 4 Hz, 0.100%_{rms} of FM rate, from the calibrator.

(3) So adjust the JIS (0.1% WEIGHTED) potentiometer of INDICATION that the meter pointer deflects to "1" scale position of the "0 ~ 1" scale.

(4) Depress the "0.3" button of RANGE % selector on the front panel.

(5) Set the FM rate of the calibrator at 0.300%_{rms}. So adjust the RANGE (%) 0.3 potentiometer that the meter pointer deflects to "3" scale position of the "0 ~ 3" scale.

(6) In a similar manner as above, adjust the RANGE (%) 1.0 and 3.0 potentiometers.

5.3.2 Level Adjustment of Mode Filter

(1) Depress front panel buttons as follows:

- * RANGE (%) 0.1
- * MODE LINEAR
- * INDICATION JIS

(2) Set the calibrator as described in Par. 5.3.1, Item (2).

771498-C

- (3) So adjust the MODE - LINEAR potentiometer that the meter pointer deflected to "1" position of the "0 - 1" scale.
- (4) Depress the WOW button of MODE selector on the front panel.
- (5) Set the wow/flutter frequency of the calibrator at 2 Hz.
- (6) So adjust the WOW potentiometer that the meter pointer deflects to "1" position of the "0 - 1" scale.
- (7) Depress the FLUTTER button of MODE selector on the front panel.
- (8) Set the wow/flutter frequency of the calibrator at 40 Hz.
- (9) So adjust the FLUTTER potentiometer that the meter pointer deflects to "1" position of the "0 - 1" scale.

5.3.3 Adjustment of INDICATION - NAB

* Adjustment for JIS has been completed by the above procedure.

- (1) Depress buttons on the front panel as follows:

* RANGE (%)	0.1
* MODE	LINEAR
* INDICATION	NAB

- (2) Set the calibrator as described in Par. 5.3.1, Item (2), except the wow/flutter frequency which must set at 40 Hz in this case.

771499

- (3) So adjust the INDICATION - NAB potentiometer that the meter pointer deflects to "1" position of the "0 - 1" scale.

5.3.4 Adjustment of INDICATION - CCIR

- (1) Depress buttons on the front panel as follows:

* RANGE (%)	0.1
* MODE	WEIGHTED
* INDICATION	CCIR

- (2) Set the calibrator as described in Par. 5.3.1, Item (2), except the FM rate which must be set at 0.100% peak in this case.
- (3) So adjust the INDICATION - CCIR GAIN potentiometer that the meter pointer deflects to "1" position of the "0 - 1" scale.
- (4) Depress the "1.0" button of RANGE (%) selector on the front panel.
- (5) Set the calibrator at wow/flutter frequency 1 Hz, FM rate 2% peak-peak square pulse, and pulse width 100 msec.
- (6) So adjust the CCIR - D1 and D2 potentiometers that the meter deflects maximum "1 ± 0.04" and minimum "0.41 ± 0.04" of the "0 - 1" scale.

* D1 potentiometer: Adjustment of maximum deflection
* D2 potentiometer: Adjustment of minimum deflection

(7) Vary the pulse width of the calibrator signal to 60 msec, 30 msec and 10 msec, and check that the maximum indicated values on the "0 ~ 1" scale are as follows:

- * 60 msec 0.9 ±0.06
- * 30 msec 0.62 ±0.06
- * 10 msec 0.21 ±0.03

(8) If the values are do not meet the above requirements, repeat the procedure starting by Item (6) above.

(9) When the above adjustment has been made, repeat the procedure of Item (1) in order to check that the meter pointer indicates "1" position of the "0 ~ 1" scale.

(10) Repeat the procedure of (1) through (9) for 2 or 3 times.

5.3.5 Adjustment of INDICATION - DIN

(1) Depress buttons on the front panel as follows:

- * RANGE (%) 0.1
- * MODE WEIGHTED
- * INDICATION DIN

(2) Set the calibrator as described in Par. 5.3.1, Item (2), except the center frequency which must be set 3.15 kHz and the FM rate which must be set at 0.100% peak in this case.

(3) So adjust the INDICATION - DIN potentiometer that the meter pointer is deflected to "1" position of the "0 ~ 1" scale.

- * If the center frequency of the calibrator is 3 kHz only, adjust the pointer to "0.952" position.

771501

* Dynamic characteristics have already been adjusted in Par. 5.3.4, Items (4) through (10) and need not be repeated here..